

ferroli



PREXTHERM RSH

High efficiency pressurised steel boilers
the best degrees centigrade



PREXTHERM RSH

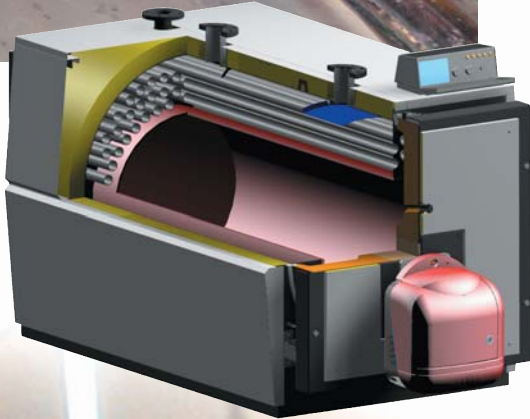

PREXTHERM RSH 80 - 800
Quadra series



PREXTHERM RSH 900 - 2600
Tonda series

The **PREXTHERM RSH** series heat generators are pressurised combustion boilers with flame reversal in the combustion chamber and three flue gas passes.

The historical experience of the Ferrolì S.p.A. Group in the design and production of steel boilers has ensured the development of a solid and reliable appliance with performance that puts it at the top of its category.

PREXTHERM RSH in fact has a three star rating according to Directive 92/42 EEC.

The main technical aspects of the design are:

- The careful design of the shapes, to ensure an optimum ratio between the combustion volumes and the heat exchange surfaces.
- The choice of materials used, for the long life of the boiler.

The range...

PREXTHERM RSH is made up of two series:

QUADRA SERIES , 12 models from 80 to 800 kW

TONDA SERIES 6 models from 900 to 2600 kW

Technical details



- The **tube bundle** has been positioned above the combustion chamber, so that the flue gas is always discharged into a "hot" environment, preventing the formation of condensate.
- The **burner is not aligned** with the combustion chamber, but rather has been moved downwards. This assists the reversal of the flame, reduces the pressure drop on the flue gas side and as a consequence extends the operating range of the generator.
- The **combustion chamber** is completely cooled (even at the rear), to ensure a greater heat exchange surface and improve the distribution of the heating load across the walls.
- The **steel body** is completely lined with an 80 mm thick layer of glass wool, in turn covered by a sturdy layer of tearproof material.

In order to increase the heat exchange between the flue gas and the central heating system, the **PREXTHERM RSH** boilers are fitted with a closed cylindrical furnace in which the flame produced by the burner is reversed from the bottom towards the door, from where the burned gas enters the rear collection chamber.



New turbulators have been designed for the **PREXTHERM RSH**, which improve the heat exchange of the flue gas and at the same time ensure a lower pressure drop than other solutions.

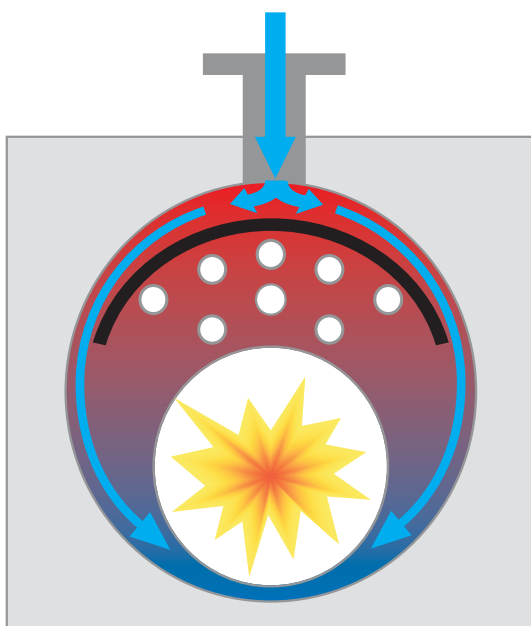

→ **Central heating water return**

A baffle plate has been fitted at the central heating system return inlet to improve the circulation of cold water towards the bottom of the boiler.

This solution ensures more uniform distribution of the heat exchange fluid across the boiler's heat exchange surface, achieving maximum heat exchange with less stress on the walls.

**FRONT DOOR**

To ensure the maximum flexibility in terms of positioning in the boiler room and assist the inspection and maintenance of the combustion chamber, the front door has been designed with a **reversible opening, either on the right-hand or left-hand side**. As well as sealing the combustion chamber, the door is an integral part of the flue gas path. Special attention has been focused on the insulation, so as to guarantee the least possible heat loss and maximum resistance to high temperatures. The door lining in the series "Quadra" is ceramic fibre, while the "Tonda" series has a double cement lining plus an extra layer of insulating material.

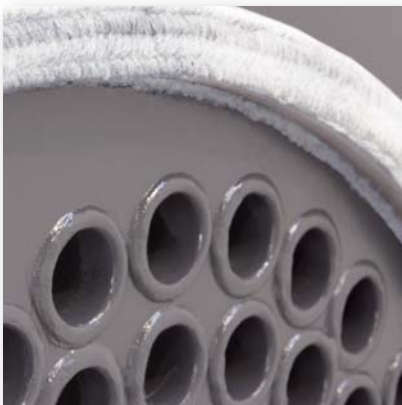

To avoid flue gas leaks at high temperatures (which may cause burning and deformations over time), the door has a **double door stop** with a **new-concept locking and centring system**. The door can be centred on the combustion chamber with just one simple operation, guaranteeing a perfect seal.

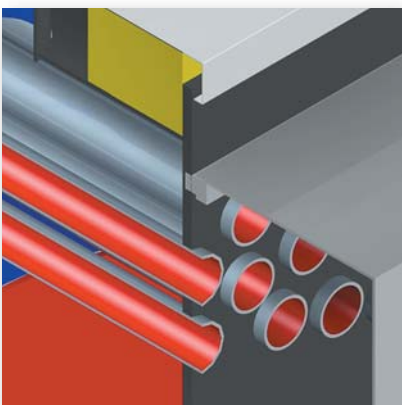
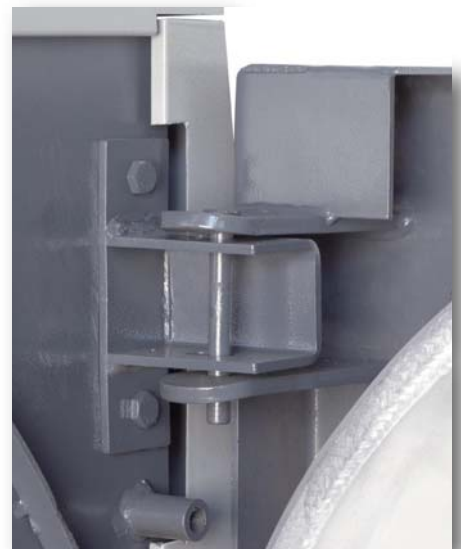

The **tube bundle** protrudes from the rear plate by a few millimetres so as to increase the temperature near the welding. This prevents the formation of condensate and the consequent corrosion of the materials.

Controls

KEY

- 1. Pump ON switch
- 2. Burner ON switch
- 3. Boiler ON switch
- 4. Test button
- 5. Safety button with manual reset
- 6. Boiler water temperature
- 7. Boiler ON LED
- 8. 1st burner flame LED
- 9. 2nd burner flame LED
- 10. Burner lockout LED
- 11. Safety pressure switch LED
- 12. 2nd boiler flame control thermostat TR1
- 13. 1st boiler flame control thermostat TR1
- 14. Space for optional temperature controller (not supplied)

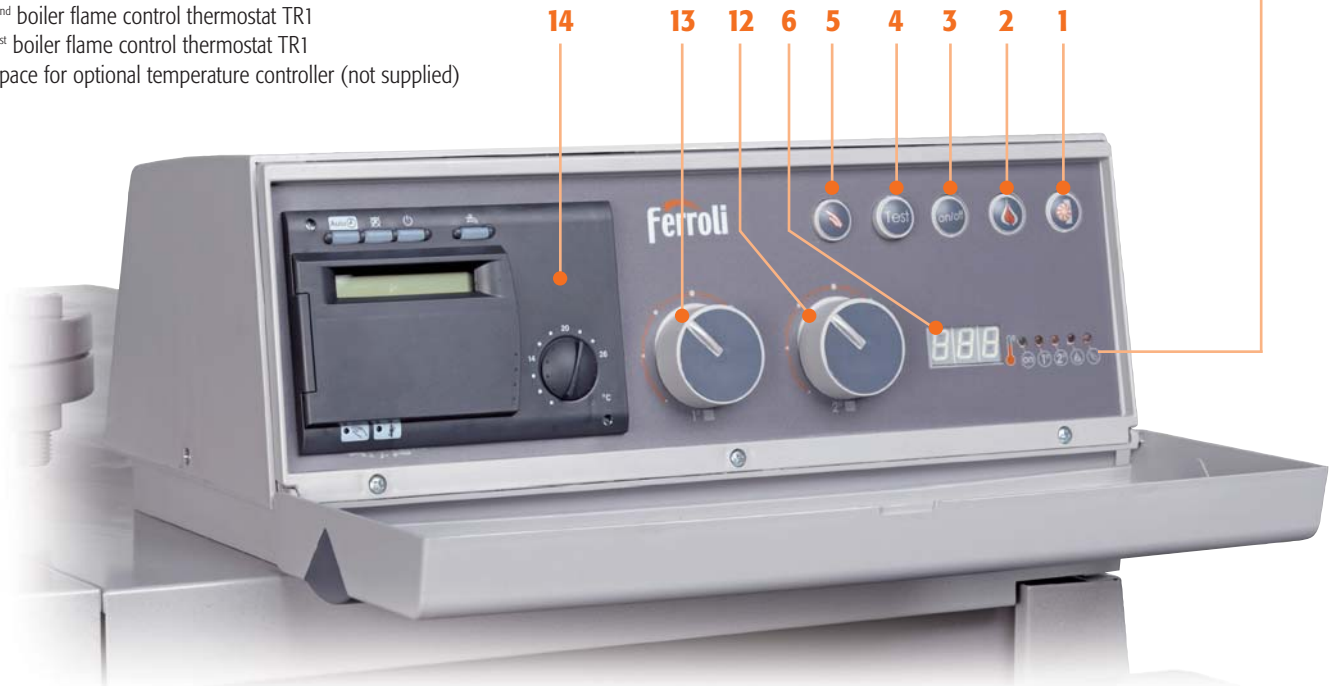
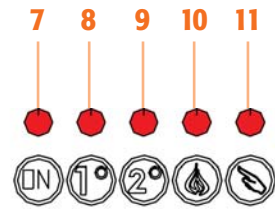

Flue gas pass diagram

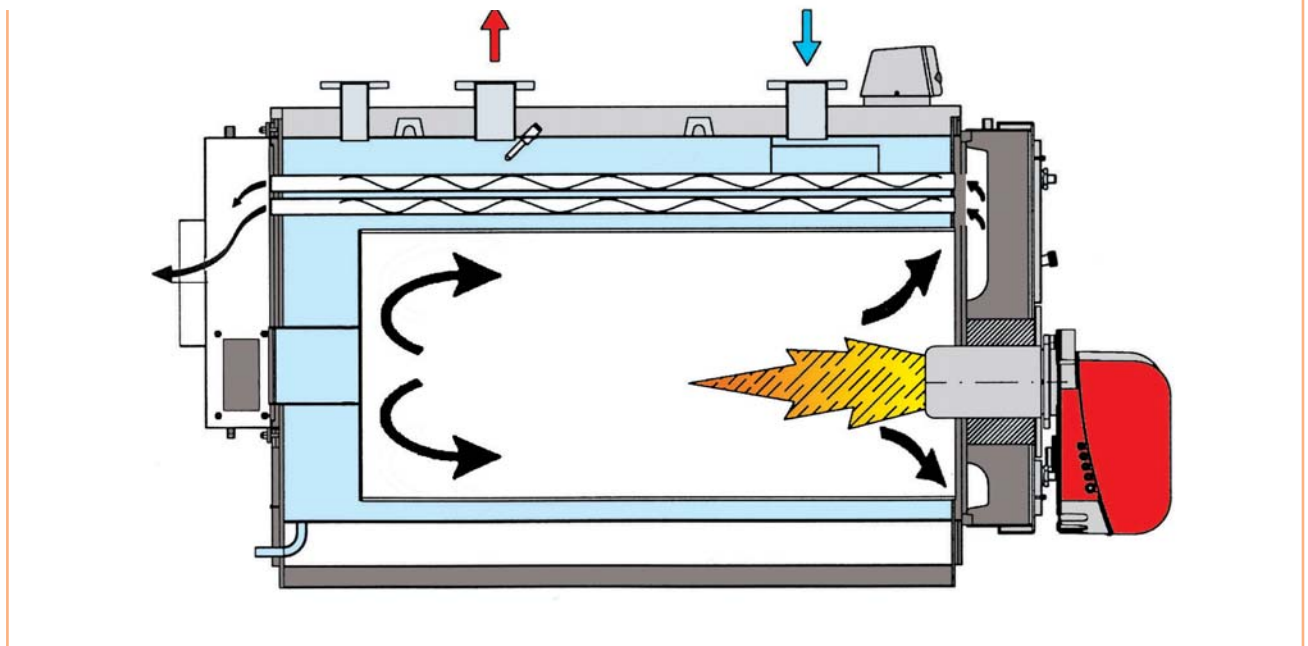

PREXTHERM RSH 80-800

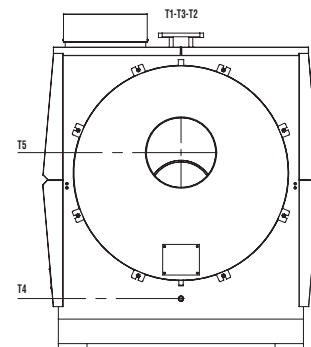
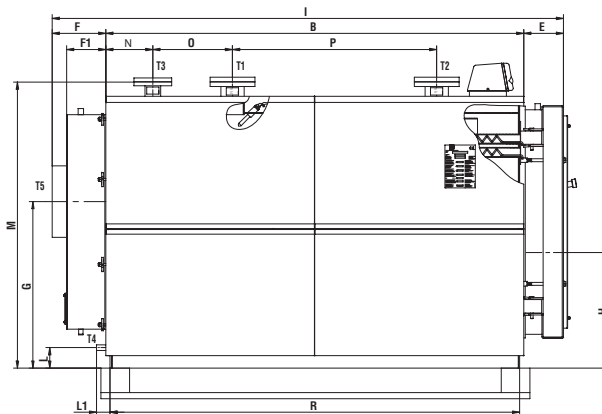
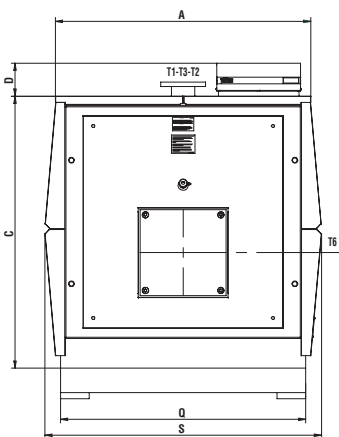

KEY

- T1 Central heating flow outlet
- T2 Central heating return inlet
- T3 Expansion vessel attachment
- T4 Boiler drain
- T5 Flue attachment
- T6 Burner attachment

PREXTHERM RSH			80	90	130	160	200	250	350	450	500	600	700	800
Rated heat output	min	kW	60	70	100	137	160	196	260	341	390	468	533	611
	max	kW	92	107	152	190	240	320	399	500	600	720	820	940
Heat input	min	kW	63,7	74,3	105,8	144,4	168,4	206	272,6	357	407,9	489,8	558,4	638,9
	max	kW	97,7	113,5	160,8	200,2	252,6	336,4	418,4	523,5	627,6	753,6	859,1	982,9
Water content		dm ³	117	154	227	283	274	326	421	498	707	802	727	819
Useful efficiency at Pn max (Tm 70°C)		%	94,19	94,27	94,52	94,92	95,02	95,15	95,37	95,52	95,62	95,56	95,47	95,65
Useful efficiency at Pn min (Tm 70°C)		%	95,40	95,50	95,75	95,44	95,71	95,84	96,06	96,21	96,31	96,25	96,16	96,34
Useful efficiency at 30% Pn max (Tm 50°C)		%	95,42	95,52	95,77	95,75	96,02	96,15	96,37	96,52	96,62	96,56	96,47	96,65
Energy marking (Directive 92/42 EEC)									★★★					
Operating pressure		bar	6	6	6	6	6	6	6	6	6	6	6	6
Water side pressure drop	Δt 10°C Δp	mbar	11	20	12	17	40	48	34	51	32	40	51	65
	Δt 20°C Δp	mbar	2	5	3	4	9	13	10	16	10	18	16	20
Flue gas side pressure drop		Δp mbar	0,7	1,2	1,2	2,3	3,3	4,4	3,3	4,8	4,5	5,6	5,4	6
Boiler weight when empty		kg	310	330	490	540	590	630	890	930	1250	1340	1410	1580
DIMENSIONS	A	mm	800	800	940	940	940	940	1050	1050	1250	1250	1250	1250
	B	mm	801	1051	1053	1303	1304	1554	1554	1854	1856	2046	2046	2306
	C	mm	911	911	1071	1071	1071	1071	1181	1181	1331	1331	1331	1331
	D	mm	165	165	165	165	165	165	165	165	165	165	165	165
	E	mm	139	139	159	159	159	159	185	185	204	204	204	204
	F	mm	164	164	164	164	164	164	254	254	254	254	254	254
	F1	mm	110	110	110	110	110	110	110	200	200	200	200	200
	G	mm	575	575	690	690	690	690	730	730	840	840	840	840
	H	mm	430	430	495	495	495	495	518	518	565	565	565	565
	I	mm	1104	1354	1376	1626	1627	1877	1993	2293	2314	2504	2504	2764
	L	mm	100	100	100	100	100	100	100	100	100	100	100	100
	L1	mm	52	52	50	50	50	50	50	50	48	48	48	48
	M	mm	980	980	1140	1140	1140	1140	1250	1250	1400	1400	1400	1400
	N	mm	176	176	180	230	230	230	228	228	230	230	230	230
	O	mm	150	250	250	350	350	400	400	400	400	390	390	650
P	mm	250	400	350	450	450	600	600	800	800	1000	1000	1000	
Q	mm	750	750	890	890	890	890	1000	1000	1200	1200	1200	1200	
R	mm	761	1011	1013	1263	1264	1514	1514	1814	1816	2006	2006	2266	
S	mm	905	905	1065	1065	1065	1065	1185	1185	1354	1354	1354	1354	
Hot water outlet	T1	DN	50	50	65	65	65	65	80	80	100	100	100	100
Hot water return	T2	DN	50	50	65	65	65	65	80	80	100	100	100	100
Expansion vessel attachment	T3	DN	1" 1/4	1" 1/4	1" 1/2	1" 1/2	1" 1/2	1" 1/2	2"	2"	65	65	65	65
Boiler drain	T4	DN	3/4"	3/4"	3/4"	3/4"	3/4"	3/4"	3/4"	3/4"	3/4"	3/4"	3/4"	3/4"
Flue gas outlet	T5	Ø	200	200	220	220	220	220	250	250	350	350	350	350

PREXTHERM RSH 900-2600

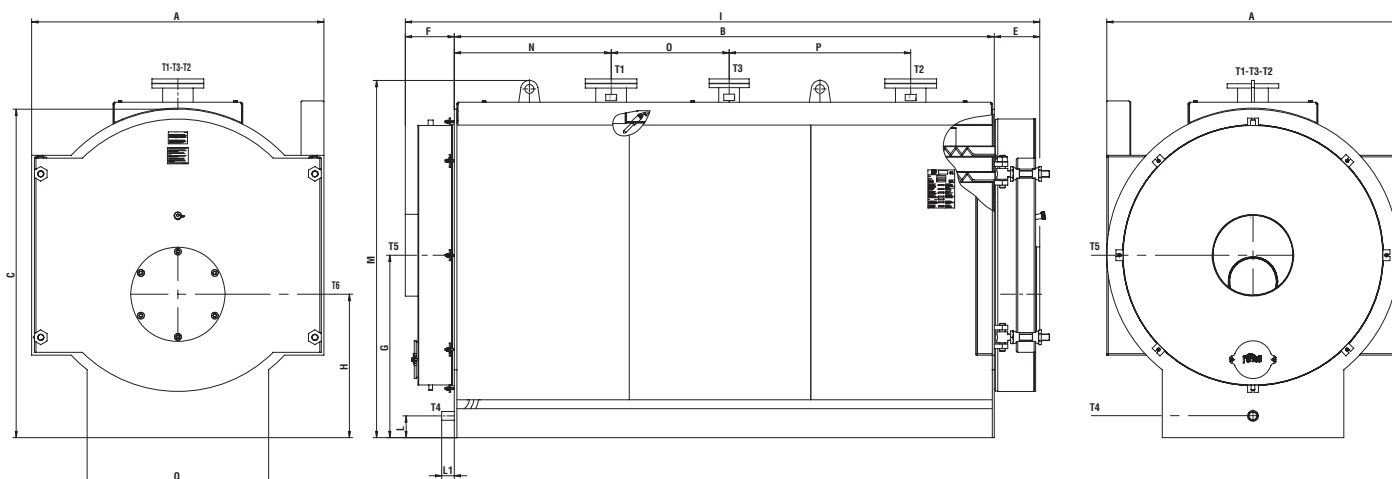

KEY

- T1 Central heating flow outlet
- T2 Central heating return inlet
- T3 Expansion vessel attachment
- T4 Boiler drain
- T5 Flue attachment
- T6 Burner attachment

PREXTHERM RSH			900	1100	1300	1600	2000	2600
Rated heat output	min	kW	689	813	962	1229	1535	1950
	max	kW	1060	1250	1480	1845	2360	3000
Heat input	min	kW	719,9	848,2	1004,4	1291,2	1603,1	2033,7
	max	kW	1107,6	1304,2	1545,2	1938	2454,7	3128,8
Water content		dm ³	1270	1363	2000	2153	3142	3276
Useful efficiency at Pn max (Tm 70°C)		%	95,72	95,86	95,80	95,60	95,77	95,90
Useful efficiency at Pn min (Tm 70°C)		%	96,41	96,55	96,49	95,80	96,39	96,59
Useful efficiency at 30% Pn max (Tm 50°C)		%	96,72	96,87	96,81	96,50	96,78	96,91
Energy marking (Directive 92/42 EEC)						★★★		
Operating pressure		bar	6	6	6	6	6	6
Water side pressure drop	Δt 10°C	Δp mbar	86	110	100	150	145	200
	Δt 20°C	Δp mbar	25	32	29	42	45	61
Flue gas side pressure drop		Δp mbar	6,5	6,8	7	7,2	7,5	7,8
Boiler weight when empty		kg	2250	2450	3350	3700	5050	5500
DIMENSIONS	A	mm	1430	1430	1660	1660	1850	1850
	B	mm	2460	2710	2724	3014	3366	3666
	C	mm	1580	1580	1810	1810	2000	2000
	E	mm	233	233	243	243	253	253
	F	mm	274	274	274	274	274	274
	G	mm	890	890	1005	1005	1100	1100
	H	mm	715	715	790	790	850	850
	I	mm	2967	3217	3241	3531	3893	4193
	L	mm	120	120	120	120	120	120
	L1	mm	71	71	69	69	67	67
	M	mm	1738	1738	1968	1968	2158	2158
	N	mm	762	812	814	864	866	866
	O	mm	500	550	550	650	1000	1000
	P	mm	700	850	850	1000	1000	1000
Q	mm	1000	1000	1000	1000	1170	1170	
Hot water outlet	T1	DN	125	125	150	150	200	200
Hot water return	T2	DN	125	125	150	150	200	200
Expansion vessel attachment	T3	DN	80	80	100	100	125	125
Boiler drain	T4	DB	1" 1/2	1" 1/2	1" 1/2	1" 1/2	1" 1/2	1" 1/2
Flue gas outlet	T5	Ø	400	400	450	450	500	500

ferroli

FERROLI *around the World*

ITALY www.ferroli.it

SPAIN www.ferroli.es

FRANCE www.ferroli.fr

UNITED KINGDOM www.ferroli.co.uk

NETHERLANDS www.agpoferroli.nl

GERMANY www.ferroli.de

TURKEY www.ferroli.com.tr

ROMANIA www.ferroli.ro

POLAND www.ferroli.com.pl

RUSSIA www.ferroli.msk.ru

UKRAINE www.ferroli.ua

BELARUS www.ferroli.by

CHINA www.ferroli.com.cn

BALKANS www.ferroli.hr

IRAN www.ferroli.ir



Ferroli spa - 37047 San Bonifacio (Verona) Italy - Via Ritonda 78/A
tel. +39.045.6139411 - fax +39.045.6100233
www.gruppoferroli.com - e-mail: export@ferroli.it

WARNING FOR TRADERS: As part of its efforts to constantly improve its range of products, with the aim of increasing the level of Customer satisfaction, the Company stresses that the appearance, dimensions, technical data and accessories may be subject to variation. Consequently, ensure that the Customer is provided with updated documents. The products described in this document are covered by warranty if purchased and installed in Italy.